

Rev.	Date	Correction	Drawn	Check
16	23-10-2022	Tilføjet skot og luge (Udgået)	MNG	JMO
17	30-11-2022	Tilføjet slingerkøl. Fjernet aksekkøle	MNG	JMO
18	30-03-2023	Tilføjet EL-tavler	MNG	JMO
19	26-04-2023	Ny placering EL-tavler. Div. indretning	MNG	JMO
20	05-07-2023	Tilføjet yderligere indretning	MNG	JMO
21	18-09-2023	Indretning ændret.	MNG	JMO
22	02-10-2023	Chiller anlæg tilføjet	MNG	JMO
23	31-10-2023	Tilføjet søjler under dæk	MNG	JMO
24	29-11-2023	Ændret søjle positioner	MNG	JMO

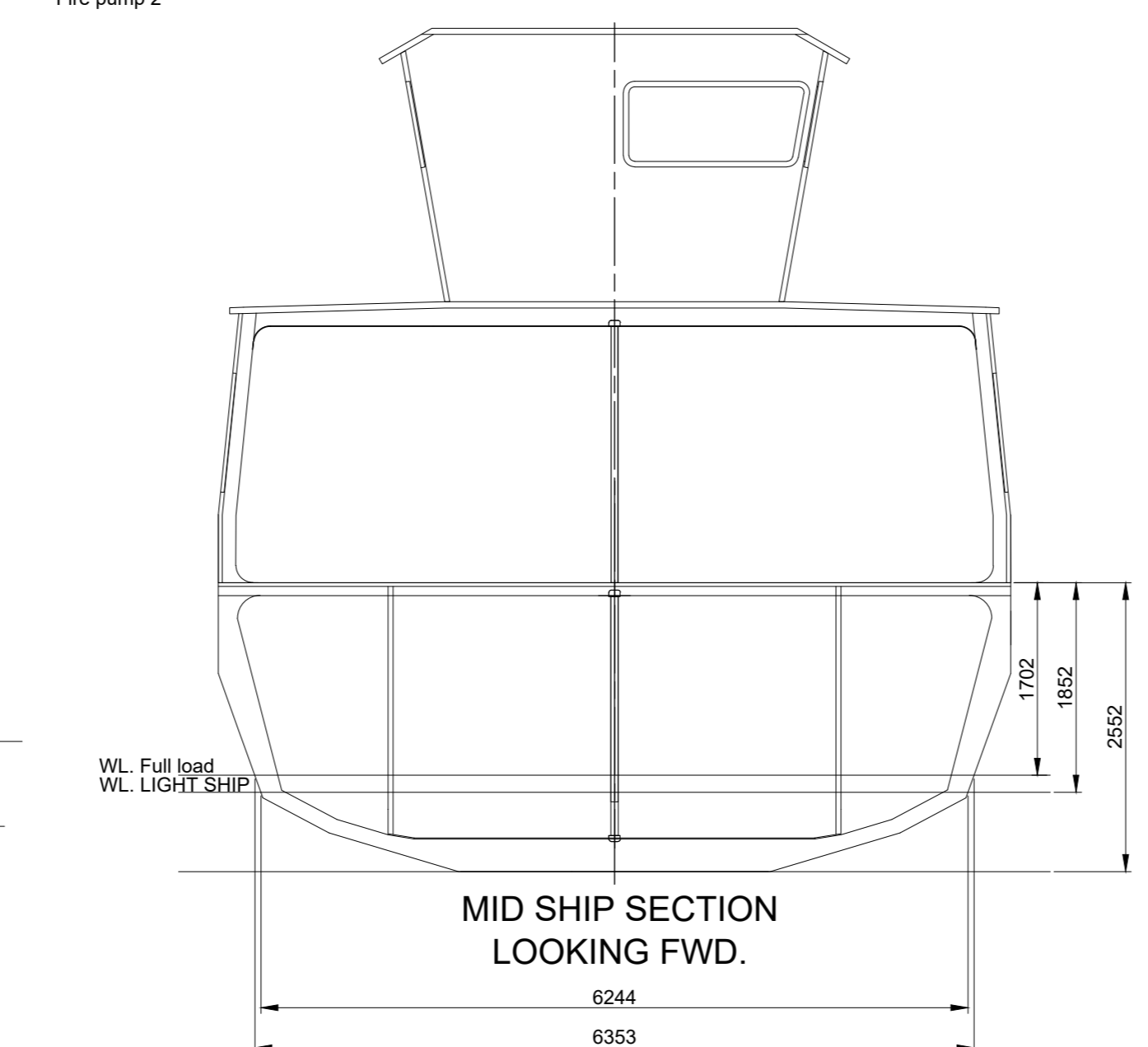
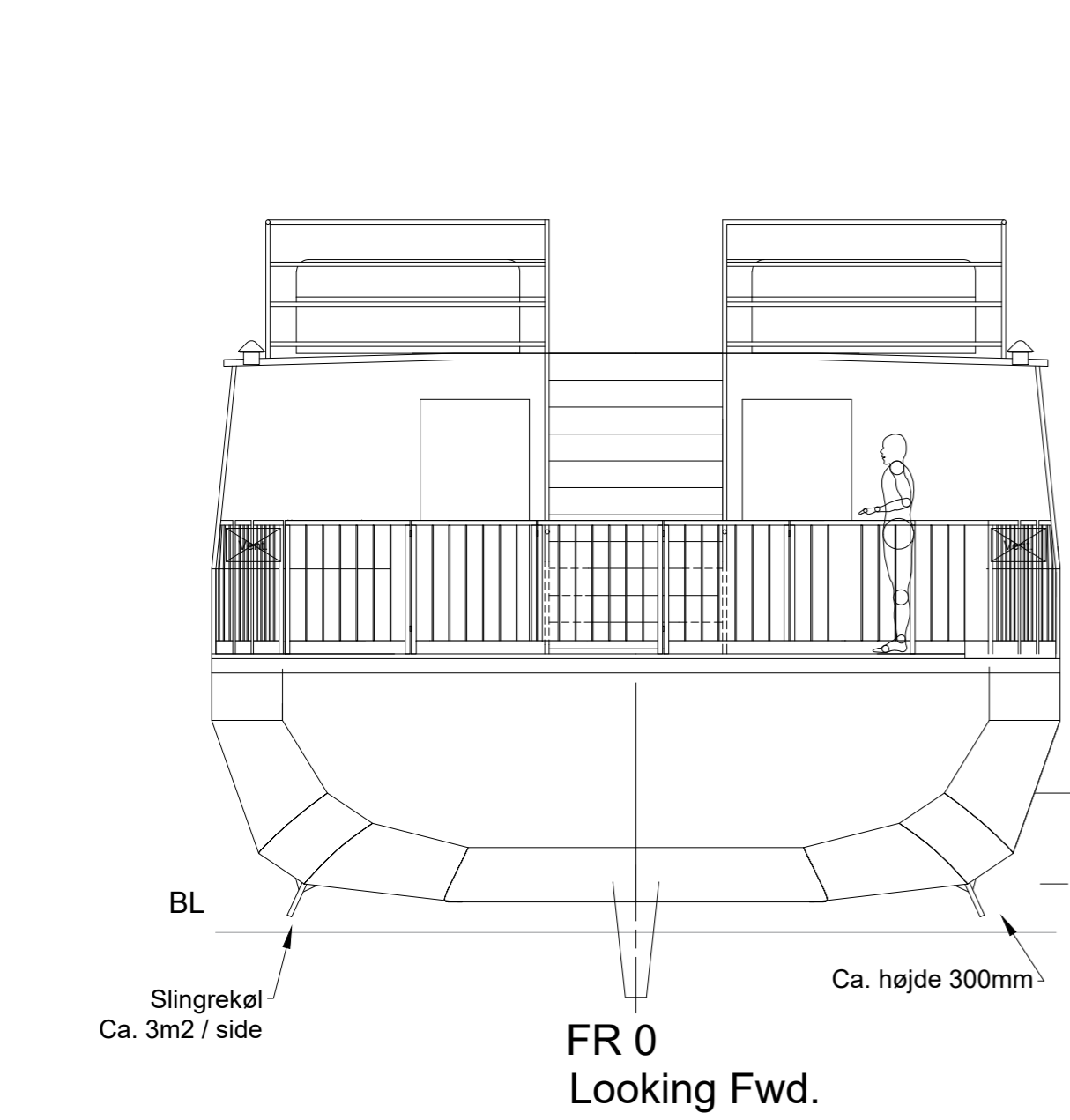
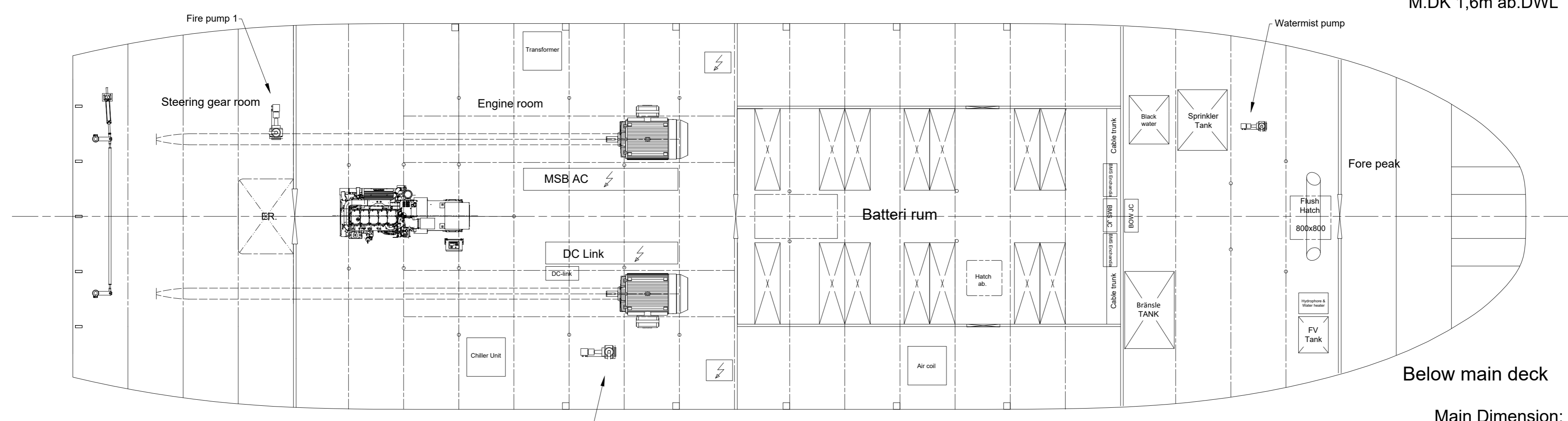
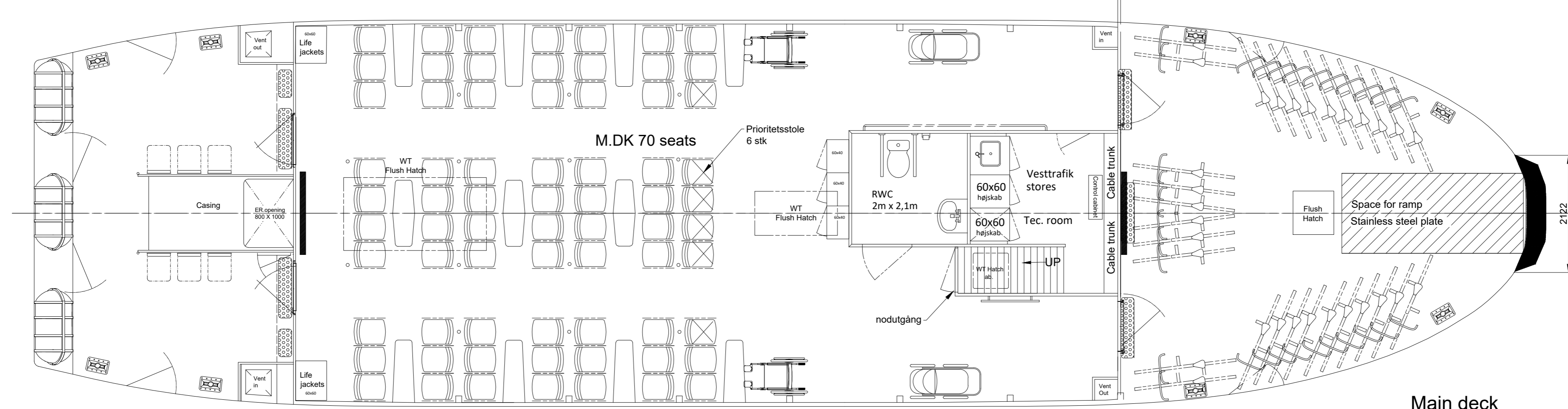
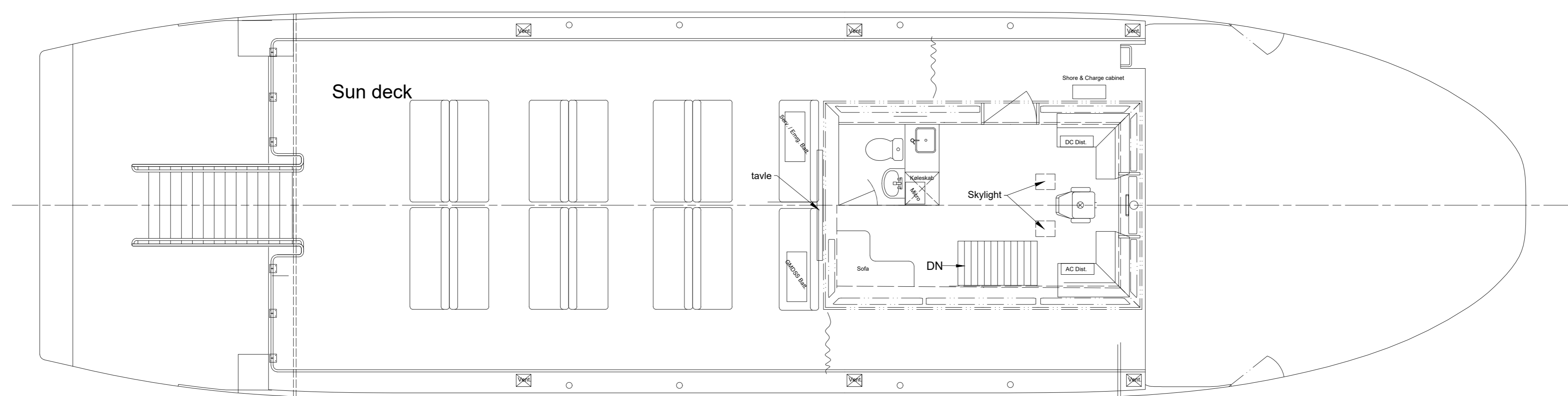
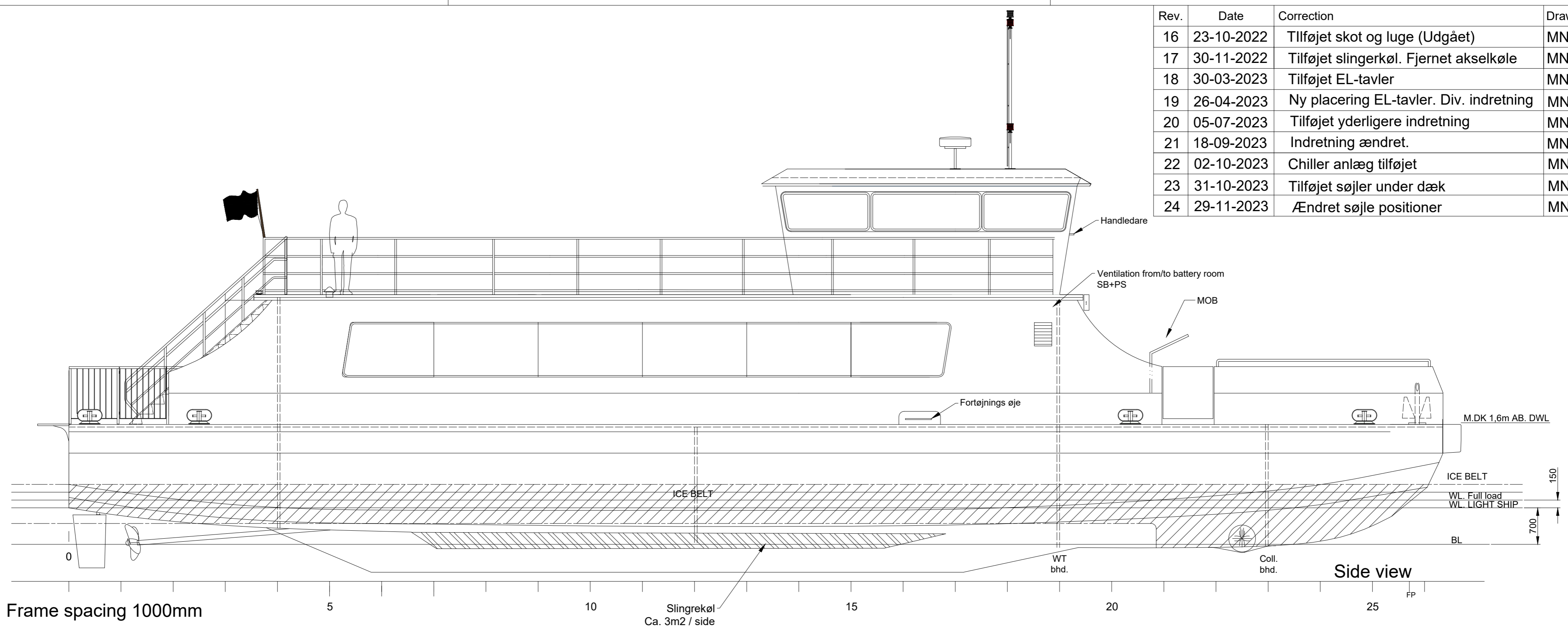

Main Dimension:

LOA hull	27,30 m
LWL	25,30 m

Beam 7,00 m

Depth 2,35 m

Draft U. keel 1,40 m

Bow thruster Electrical Ø513 mm

Speed 11 Knot

Hull Construction: GRP

Ice strengthening NBS Y33 (5 cm solid ice)

Superstructure Construction: GRP

Capacities:

Passengers:	150 Pax.
Wheel chairs:	2
Baby carriages:	2
Bicycles:	30
Bränsle:	1700 liter
Sprinkler water:	1000 liter
Black water:	750 liter
Fresh water:	300 liter

FAABORG VÆRFT A/S
SHIPYARD · NEWBUILDING · REPAIR

Værftsvvej 7, DK-5600, +45 62 61 21 10, fv@faaborg-vaerft.dk

SKALA: 1:60

VESEL NR.: 1161

VESEL TYPE: Faaborg Passenger Ferry

CLIENT: Gunnars Båtturer & Charter AB

VESEL NAME: Elise

TEGN. NR.: 1161.01.01

TEGN.: MNG

DATE: 29.11.23

ANSV.: MNG

FORMAT: A2

REVISION: 24

TEXT: GENERAL ARRANGEMENT

This document is the property of Faaborg Værft A/S and shall not be shared with any third party without written acceptance